

DIII-D ERROR FIELD AND MODELING

by

M.J. Schaffer¹

with contributions and help from

**M.S. Chu¹, T.E. Evans¹, R.J. La Haye¹, A.M. Garofalo², T.C. Hender³,
G.L. Jackson¹, L.L. Lao¹, J.A. Leuer¹, J.L. Luxon¹, S.B. Mahar⁴, J.T. Scoville¹**

¹General Atomics

²Columbia University

³EURATOM / UKAEA

⁴MIT

Presented at the Post-APS Error Magnetic Field Workshop

Albuquerque, NM

2003 Nov 01–02

CONTENTS

- **Introduction and Background**
- **Error Measurements in DIII-D**
- **Modeled Effects of DIII-D Errors**
- **Discussion and Conclusion**

Introduction

- Non-axisymmetric magnetic errors can have deleterious effects.
- Many of the DIII-D errors are known (re measured in 2001 Nov).
 1. Non-coaxiality among Poloidal- and Toroidal-field coils.
 2. Toroidal-field coil bus near coil feed points.
- A correction coil set (**C-coil**) compensates errors in DIII-D since 1994 using a substantially *empirical* algorithm. It *is* effective!
- The C-coil algorithm does **NOT** null the errors:
 - ⇒ Its toroidal phase is \approx right to cancel islands on $q=2$ surface,
 - ⇒ but its magnitude is 3–4 times *too large*.
- **I-coil** experiment implies an error 2–4 times *smaller* than C-coil.
- How does the plasma adjust to this large empirical “overcorrection”?

We want to understand interactions among
magnetic field errors, plasmas, & imperfect corrections
to rationally design correction for DIII-D & future fusion experiments.

DIII-D Magnet Coils of Interest in This Paper

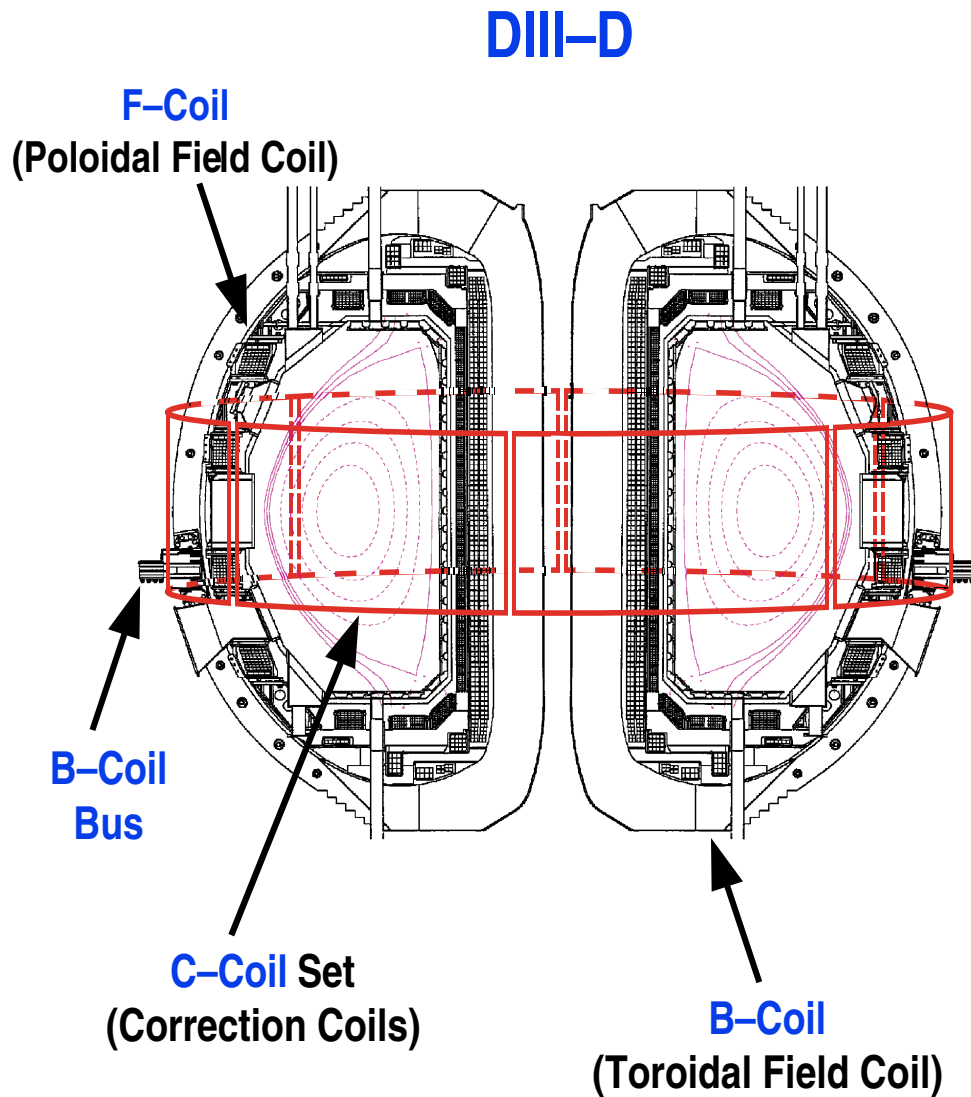

F-Coils (Poloidal Field Coils)

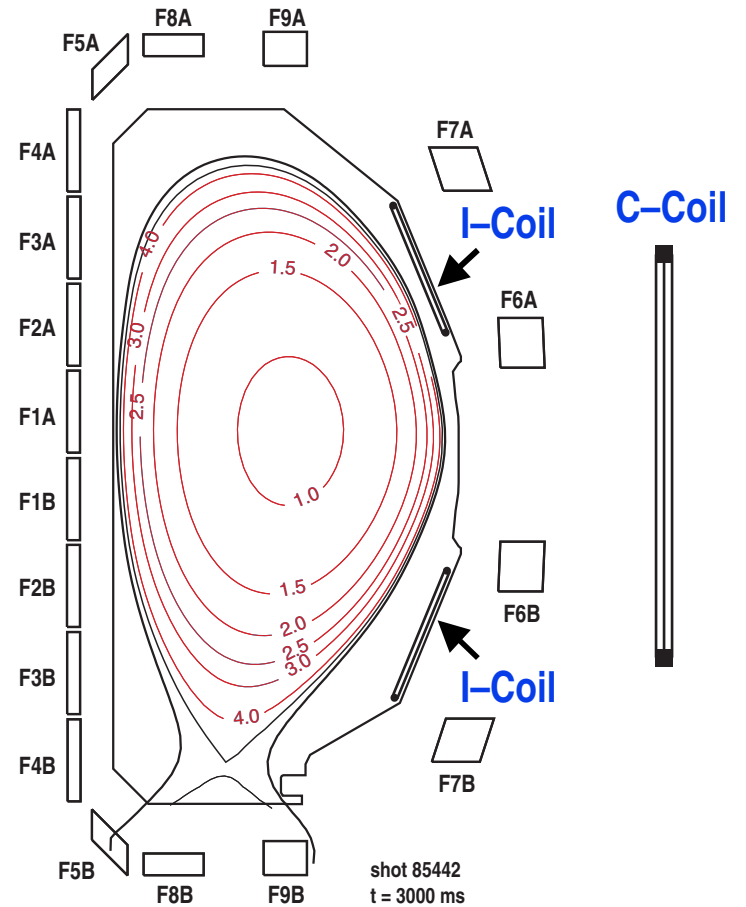

shot 85442 plasma with **q** surfaces
(from C-coil correction-development experiments)

Brief History of Magnetic Errors at DIII-D

- 1990: Measured F-coil errors of DIII-D. (La Haye & Scoville)
- “N=1 Coil” demonstrated partial error correction experimentally. (La Haye & Scoville)
- 1994: C-coil (Correction coil) installed.
- 1994–97: Developed C-coil correction algorithm empirically with theoretical guidance, to minimize locked modes. (La Haye & Scoville)
 - Ohmic, low momentum input, low density plasmas prone to locked modes. Had $q=1$ surface.
 - Empirical algorithm does much more than simply cancel F-coil errors measured in 1990.
It is dominated by a term proportional to B_{TOr} .
- 2000–1: Empirical algorithm, with small changes, optimized plasma rotation in Resistive Wall Mode (RWM) study discharges. (A. Garofalo)
 - Rotationally stabilized; high β , resonant error amplification; no $q=1$ surface.
- Algorithms from both mode locking and RWM shots were interpreted to be canceling a substantial B_{TOr} (equivalent to $m,n = 2,1$ component ~ 7 G at $q=2$ surface).
 - No such error in DIII-D was known (J. Luxon).
- 2001–2: Thorough measurement of magnetic errors in DIII-D. (Schaffer et al.)

ERROR MEASUREMENTS

In-Vessel Array, Illustrating Magnetic Pickups and Hoist



In-Vessel Probe Array for Error Measurements was Rebuilt

- Octagonal frame disassembles to enter DIII-D (LaHaye).
- Frame slides vertically along four legs.
- Planar spiral inductive probes on printed circuit boards, $NA \sim 1 \text{ m}^2$. (Jackson).
- 3 components (B_R , B_ϕ , B_Z), each at 8 toroidal locations.
- Reassembly inside DIII-D
 - Must maintain planarity, circularity and centering of the *array*.
 - Must maintain orientation of the *probes*.

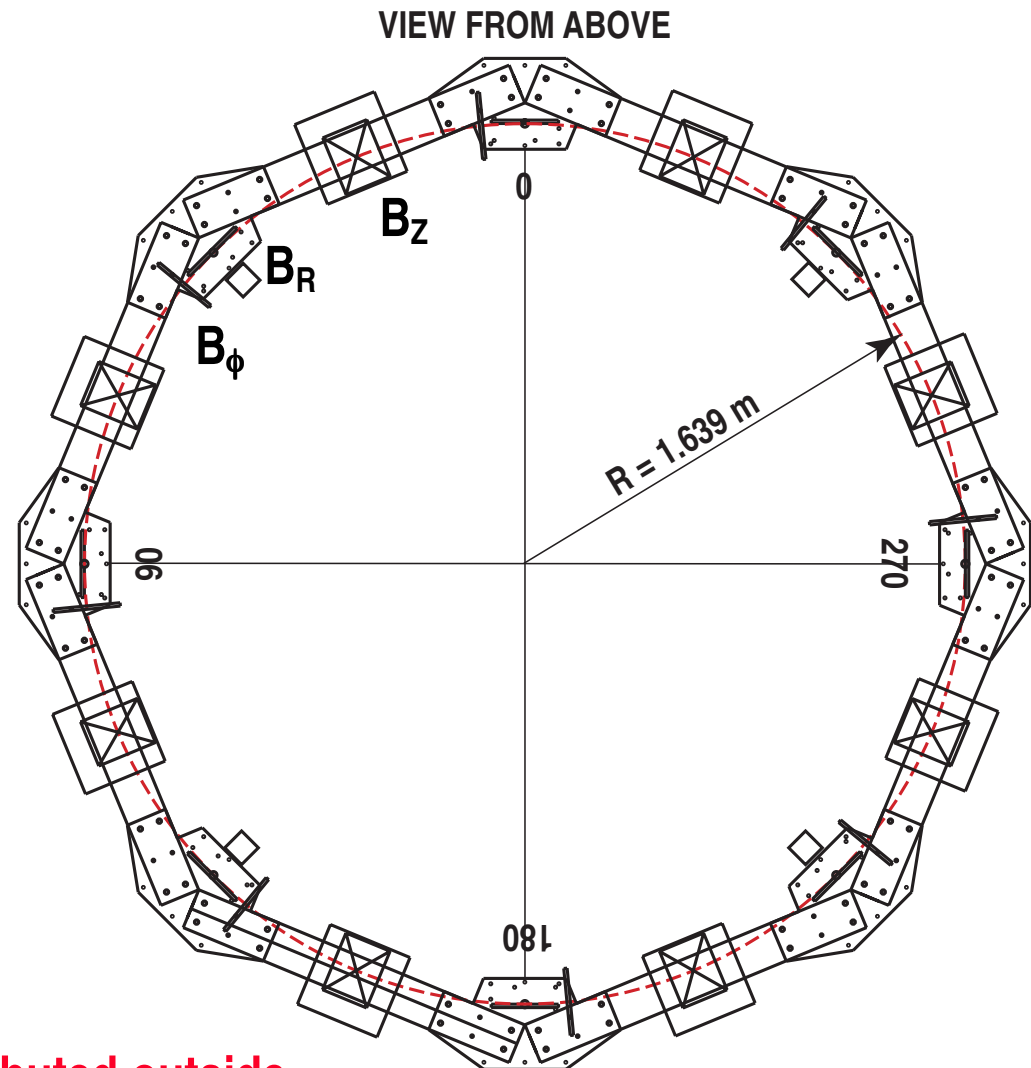

- Other probes distributed outside B-coil and in its central bore.

Measurement Coordinate System Is Chosen for Ability to Reproduce It

- All in-vessel measurements made in one reproducible vertical cylindrical coordinate system (right handed).

After every change of array position:

- Make array level and flat to gravity
- Center probe circle on vessel inner wall
 - 8 radial scales bolted to vessel
 - 8 plumb bobs hang from probe array
 - $\approx \pm 0.5$ mm centering reproducibility
- Check array circularity
- Level B_z probes. Plumb B_R and B_ϕ probes.
 - $\approx \pm 0.0005$ rad $\approx \pm 0.03^\circ$ reproducibility

Also:

- Rotated array 65° once, to separate probe errors from true δB , also to synthesize 16 element array.

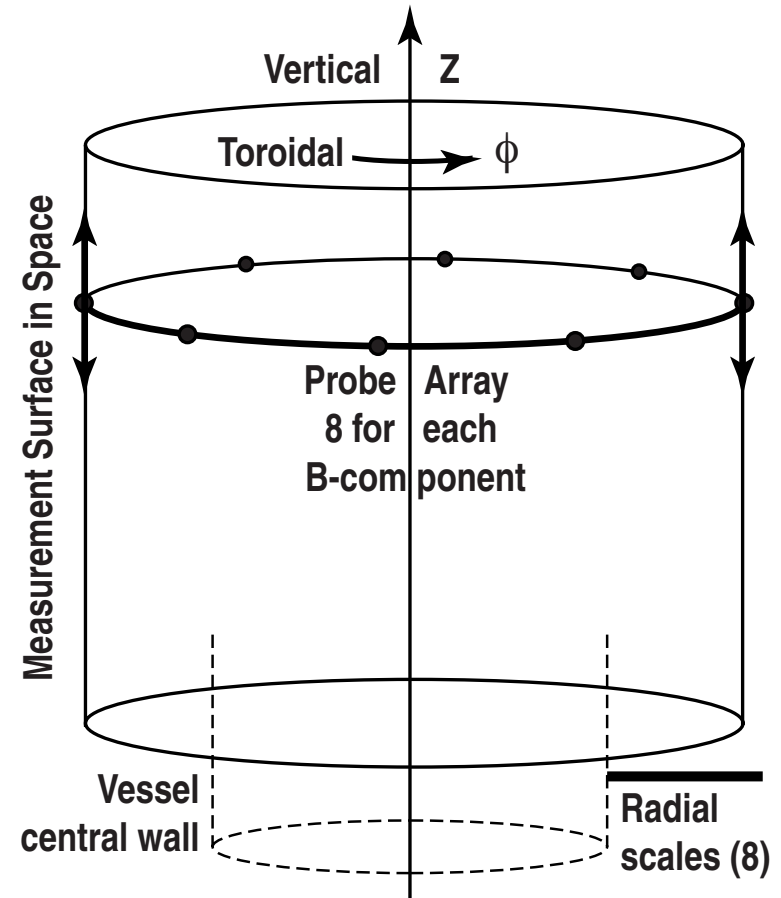

MEASUREMENT RESULTS

Measured F-Coil Axes Are Also Tilted with Respect to the Toroidal Magnetic Field

- Newly measured tilts are less than inferred from 1990 measurements.
- The old $N = 1$ coil ferromagnetic frame tilted the fields of the uppermost F-coils in 1990.

Points on figure show tilt of coil midplane, upward at the toroidal angle shown (Luxon convention).

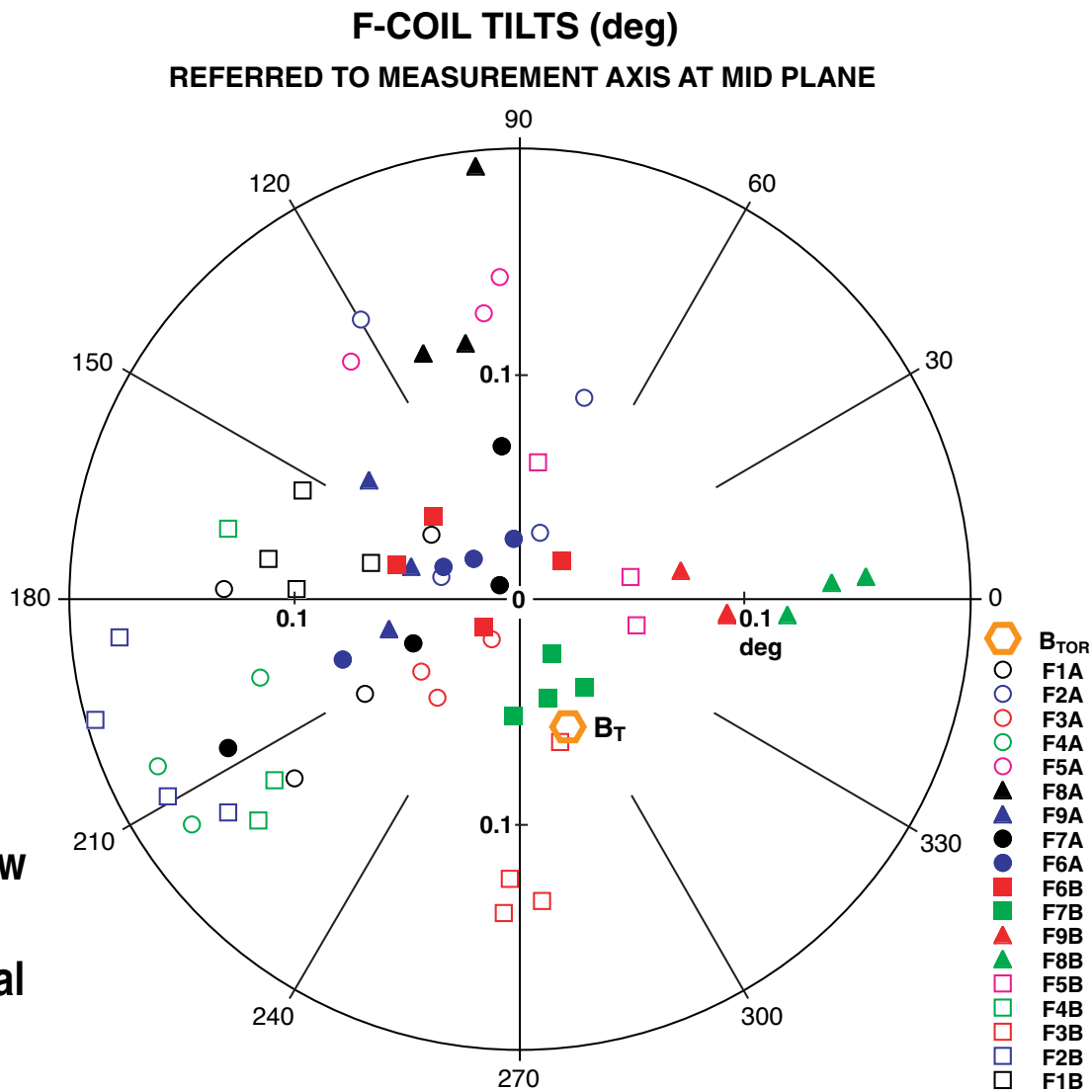

Other Errors

- B-coil Bus errors near feed points are comparable in magnitude to the F-coil non-coaxiality errors.
 - The bus error field is barely distinguishable from background B_{Tor} in our measurements with the internal array. However, it was readily detected by probes placed outside the B-coil envelope.
- Other errors are smaller:
 - Centerpost nonuniformities
 - Old “N = 1 coil” frame
 - Iron diagnostic shields
- No large new error source was found.

MODELING

Numerical Tools

- DIII-D version of the **TRIP3D** magnetic line tracing code (by T.E. Evans)
- Fourier harmonic (m,n) error analysis code **SURFMN** (by M.J. Schaffer, 2003)
 - Both codes...
 - Obtain axisymmetric equilibrium B from EFIT
 - Independently shift and tilt *plasma-generated* toroidal and poloidal B
 - Model *externally-generated* vacuum field contributions realistically
 - F-coils and B-coil with measured positions and tilts
 - B-coil bus (2003)
 - C-coil (set of 6 ex-vessel coils)
 - I-coil (new set of 12 in-vessel coils) (2003)
- Surface error minimization codes (by M.J. Schaffer & S. B. Mahar, 2003)

Magnetic Line Tracing Model Results: Off-Center F-Coils Alone Make Modest (≈ 2 cm-wide) 2,1 Islands, if Plasma Current Follows B_T

Plasma Current Centered on B_T . No C-Coil Current.

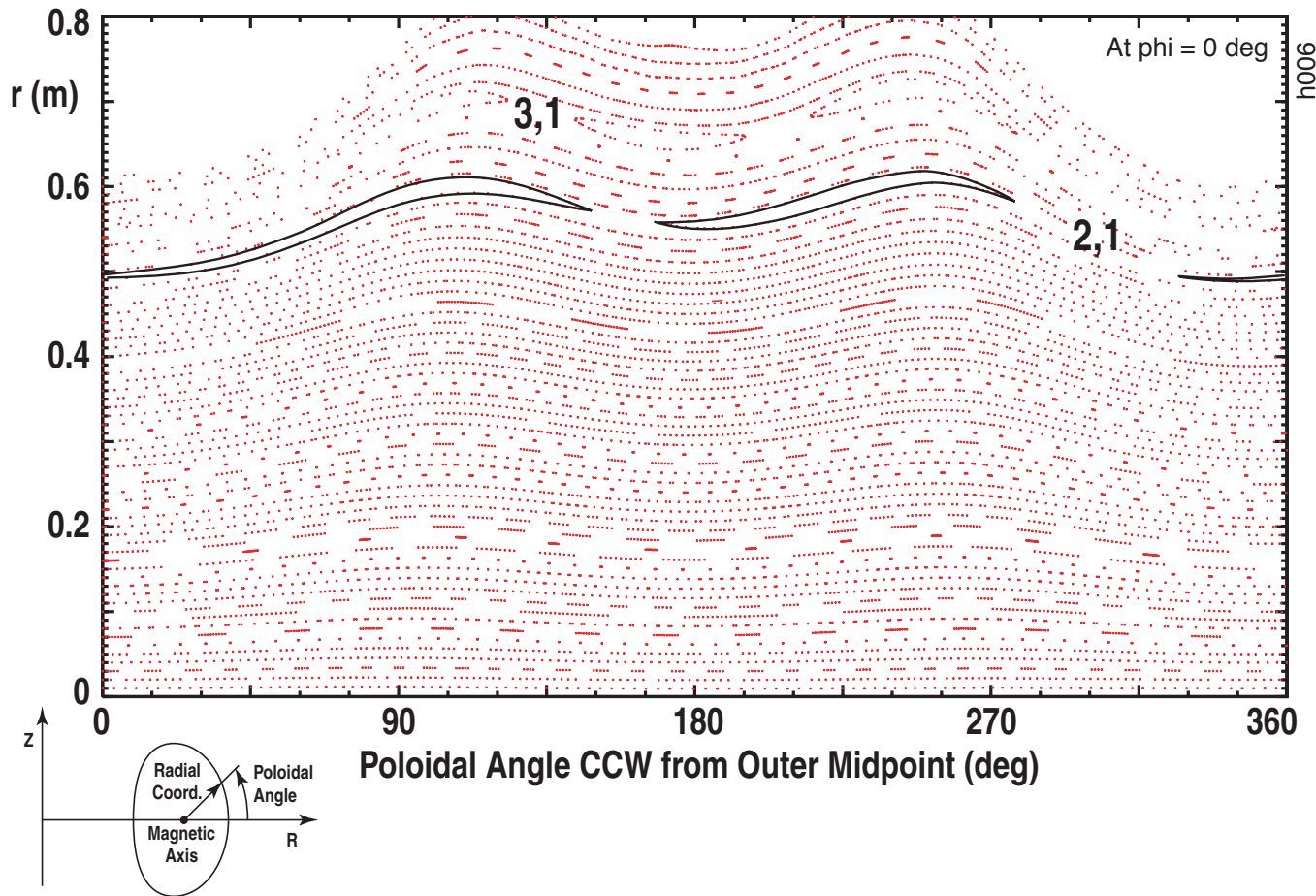

Equilibrium fields are from **shot 102115**, $q(0) \approx 1.13$
 Limited, nearly circular ($\kappa \approx 1.15$)

For Simplicity

MODEL:

**Measured Coil Centers
& Currents.**

(2002, No tilts)

**Plasma Currents are
Aligned with Vacuum B_T .**

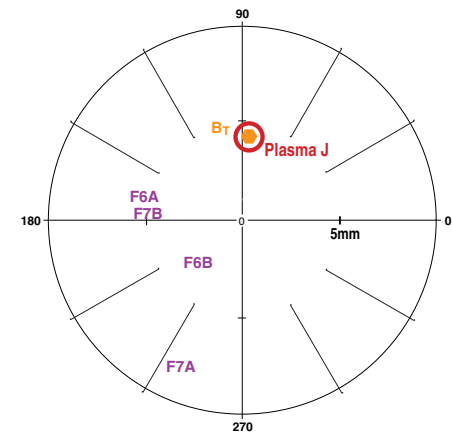

Illustrating F-Coils,
 B-Coil & Plasma Centers
 in Measurement & Code
 Coordinates.

Magnetic Line Tracing Model Results: Adding Experimental C-Coil Field Makes **LARGE** (≈ 6 cm) 2,1 Islands if Plasma Current Follows B_T

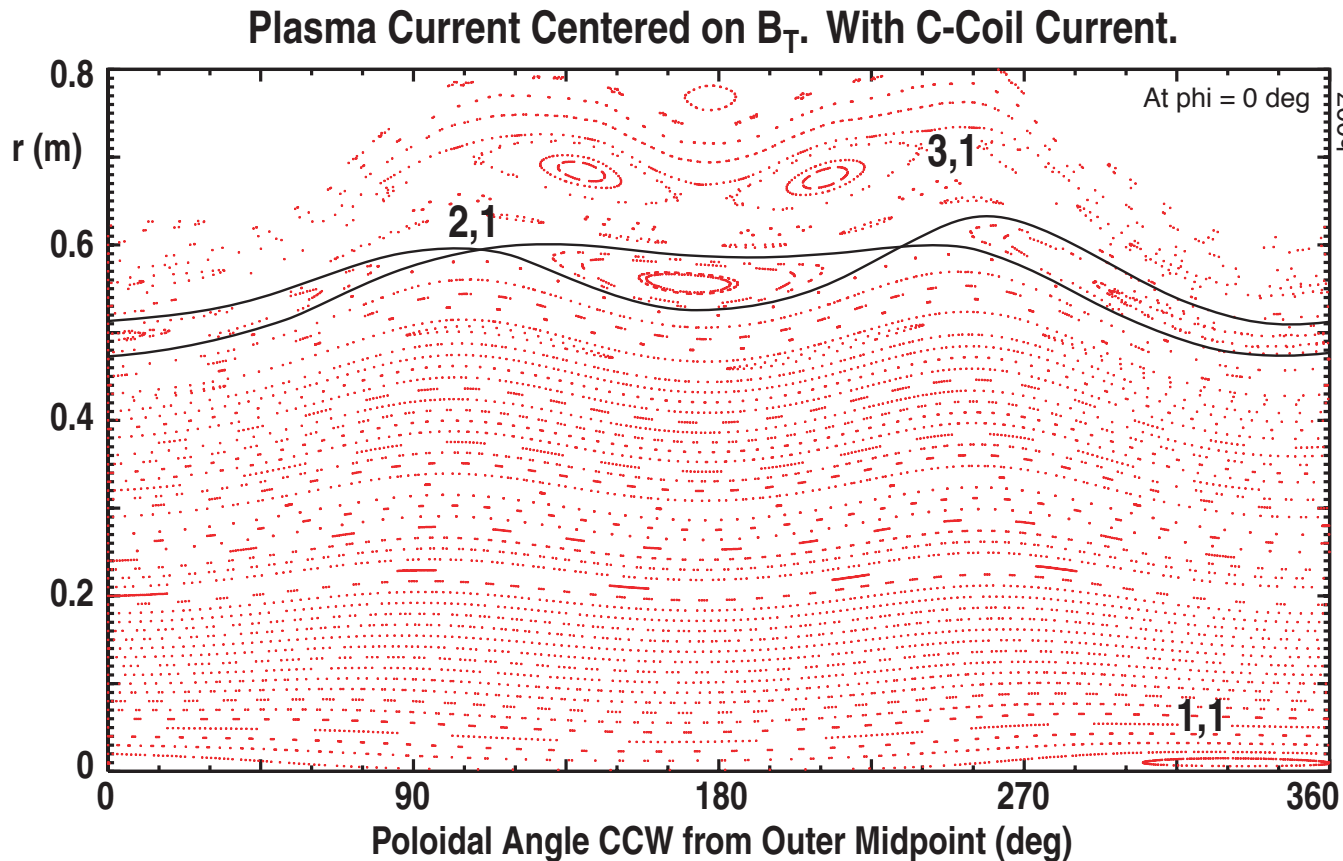

MODEL:

Measured F-, B- and C-Coil Geometry & Currents.
 (2002, No tilts)

Plasma Currents are Aligned with Vacuum B_T .

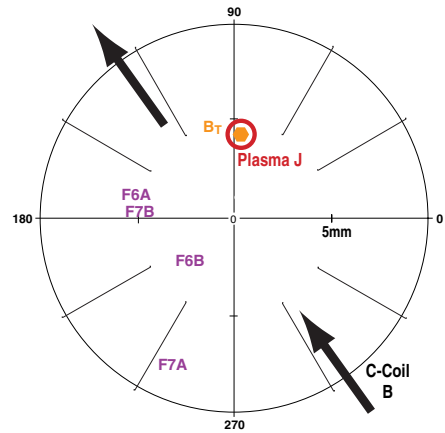

- It appears that the C-coil does not achieve its empirical correction by moving the external poloidal B so that all B and J components are more or less centered on B_T .

shot 102115

Magnetic Line Tracing Model Results: Adding Experimental C-Coil Field Makes Still LARGER Islands if Plasma Current Centers on External B_{pol}

Plasma Current Centered Near F-Coils (5 mm $\Rightarrow \phi = 220^\circ$). With C-Current.

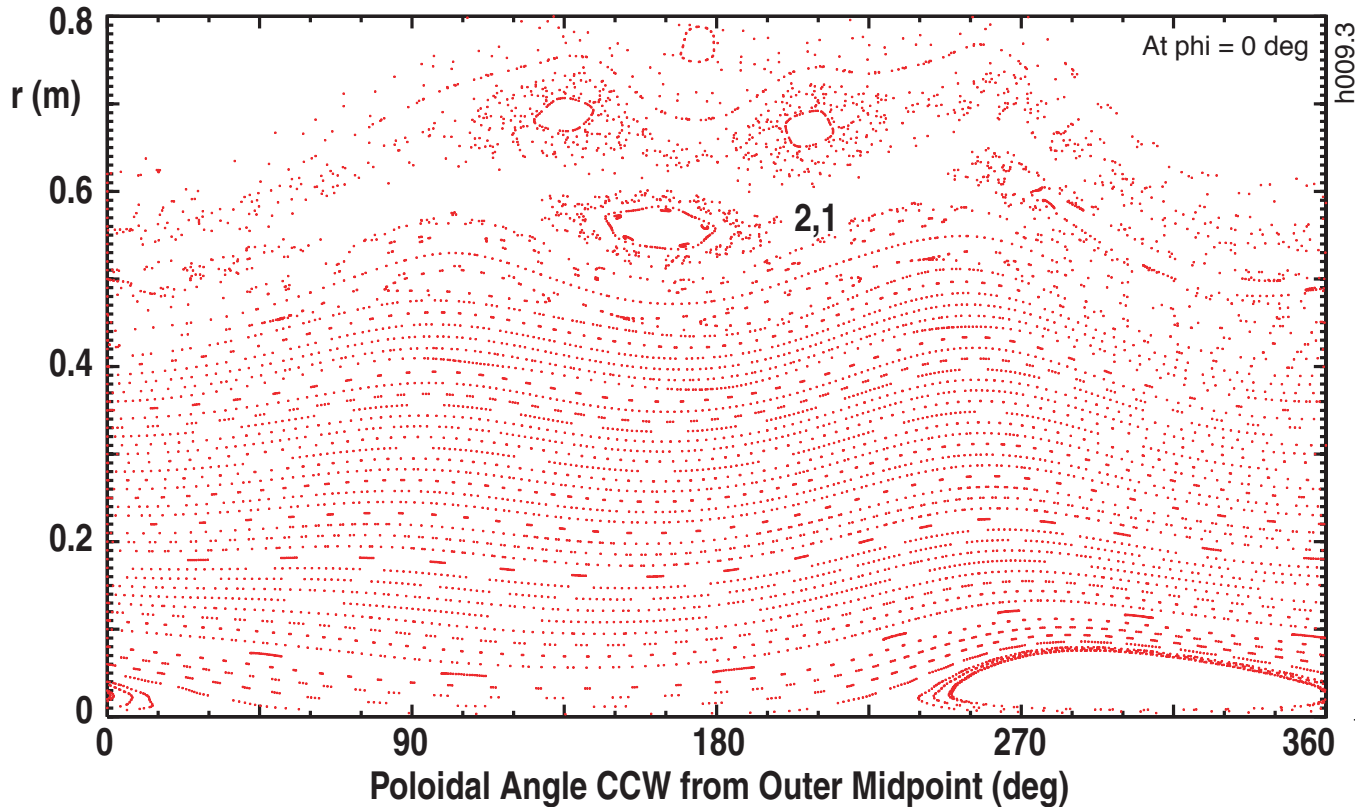

MODEL:

Measured F-, B- and C-Coil Geometry & Currents.

(2002, No tilts)

Plasma Currents are \approx Aligned with F-Coils

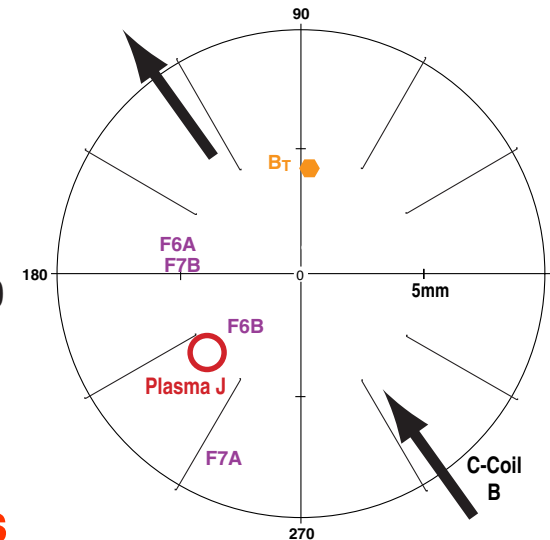

- It appears that the C-coil does not achieve its empirical correction by moving B_T so that all B and J components are more or less centered on the external poloidal B.

shot 102115

F-Coils' Non-Coaxiality Makes Moderate Islands at $q = 2$ & 3. Makes Large $q=1$ Island, Due to Low Magnetic Shear There.

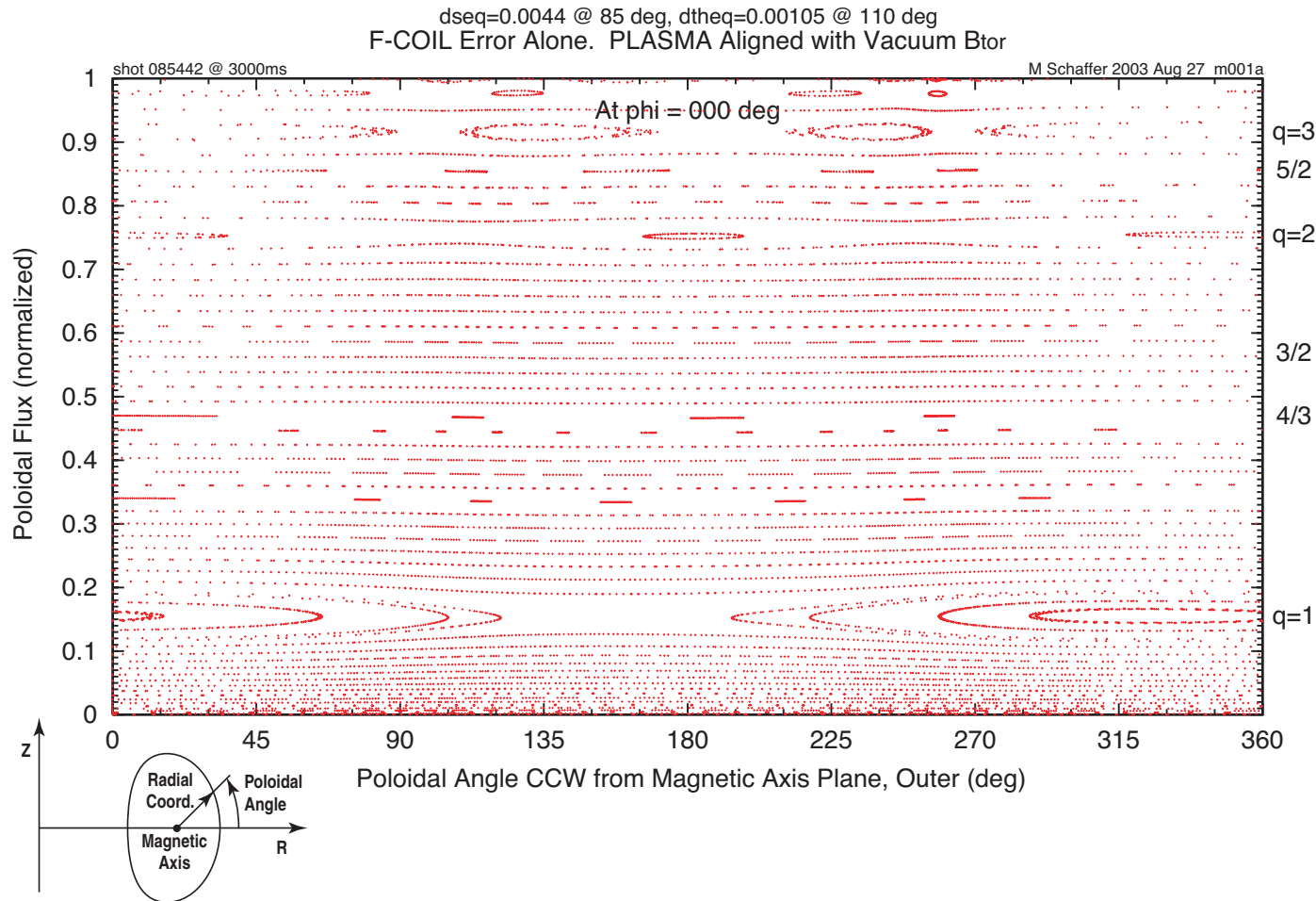

Equilibrium fields are from **shot 85442**, $q(0) \approx 0.9$, one of shots used to develop C-coil correction algorithm.

The higher-m poloidal harmonics arise largely from low aspect ratio and shaped poloidal cross section.

MODEL:

Measured Coil Centers, Tilts, & Currents. (2003)

Plasma Currents are Aligned with Vacuum B_T .

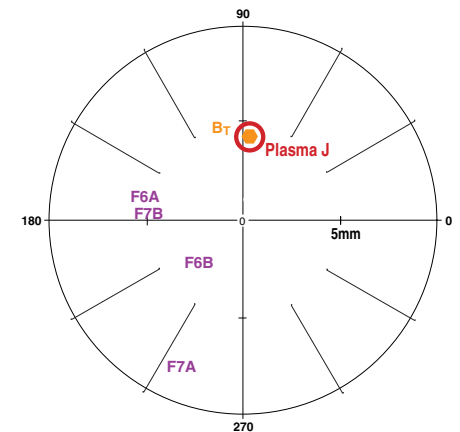

Illustrating Some F-Coils, B-Coil & Plasma Centers in Code Coordinates.

Tilt makes less error than shift.

B-Coil Bus Error Makes Islands on Integer-q Surfaces, and Its Higher Toroidal Harmonics Make Additional Islands ($n = 2, 3, \dots$).

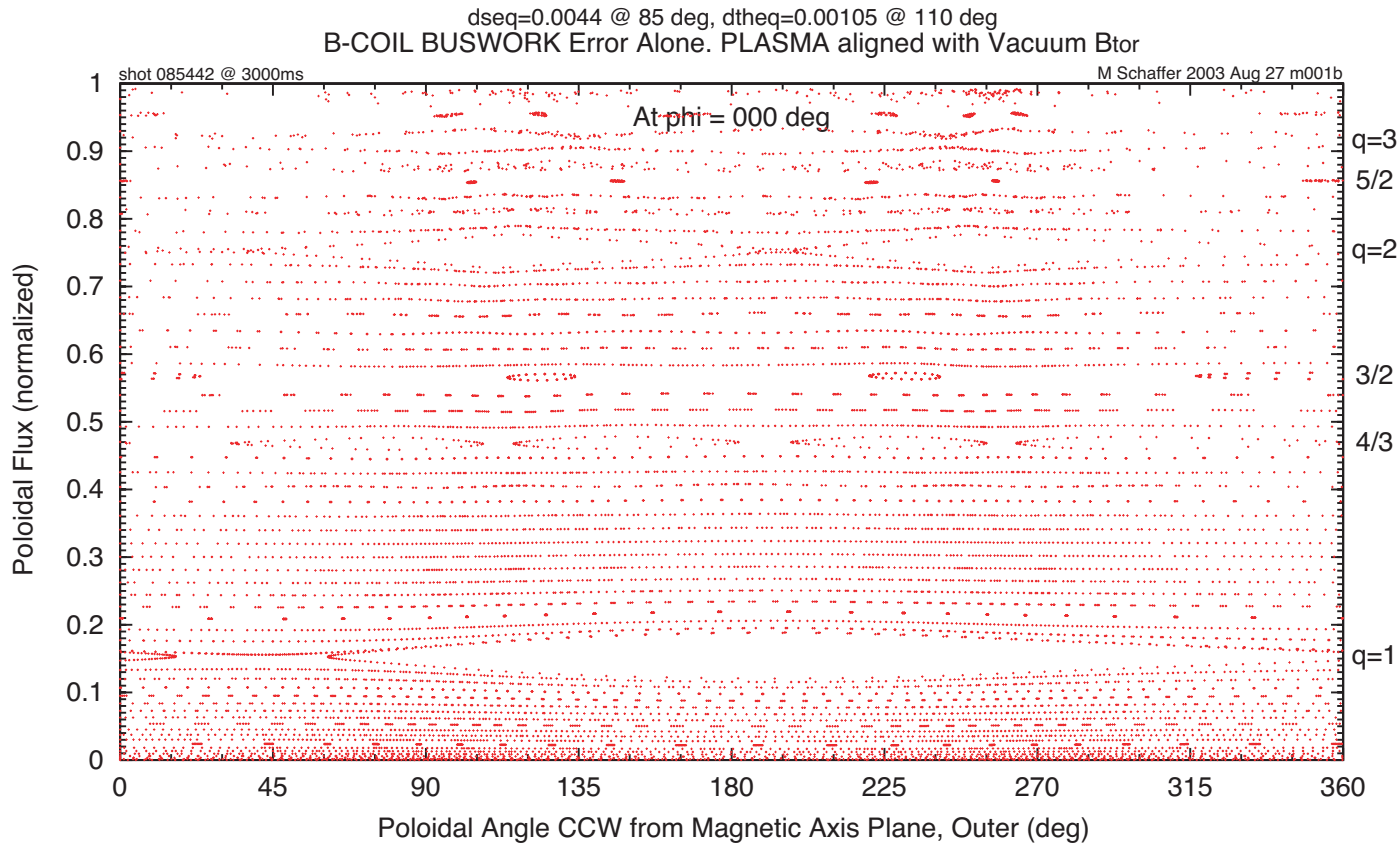

MODEL:

B-Coil Bus Error.
(2003)

Plasma Currents are
Aligned with Vacuum B_T .

shot 85442

- Bus and F-coil errors are roughly out of phase at $q=2$ and $q=3$.
- $m,n = 4,2$ and $6,3$ harmonics are visible at $q=2$; $m,n = 6,2$ and $9,3$ at $q=3$.

Quantified by surface Fourier analysis.

F-coil & B-Bus Combined Are the Major “Intrinsic” Errors

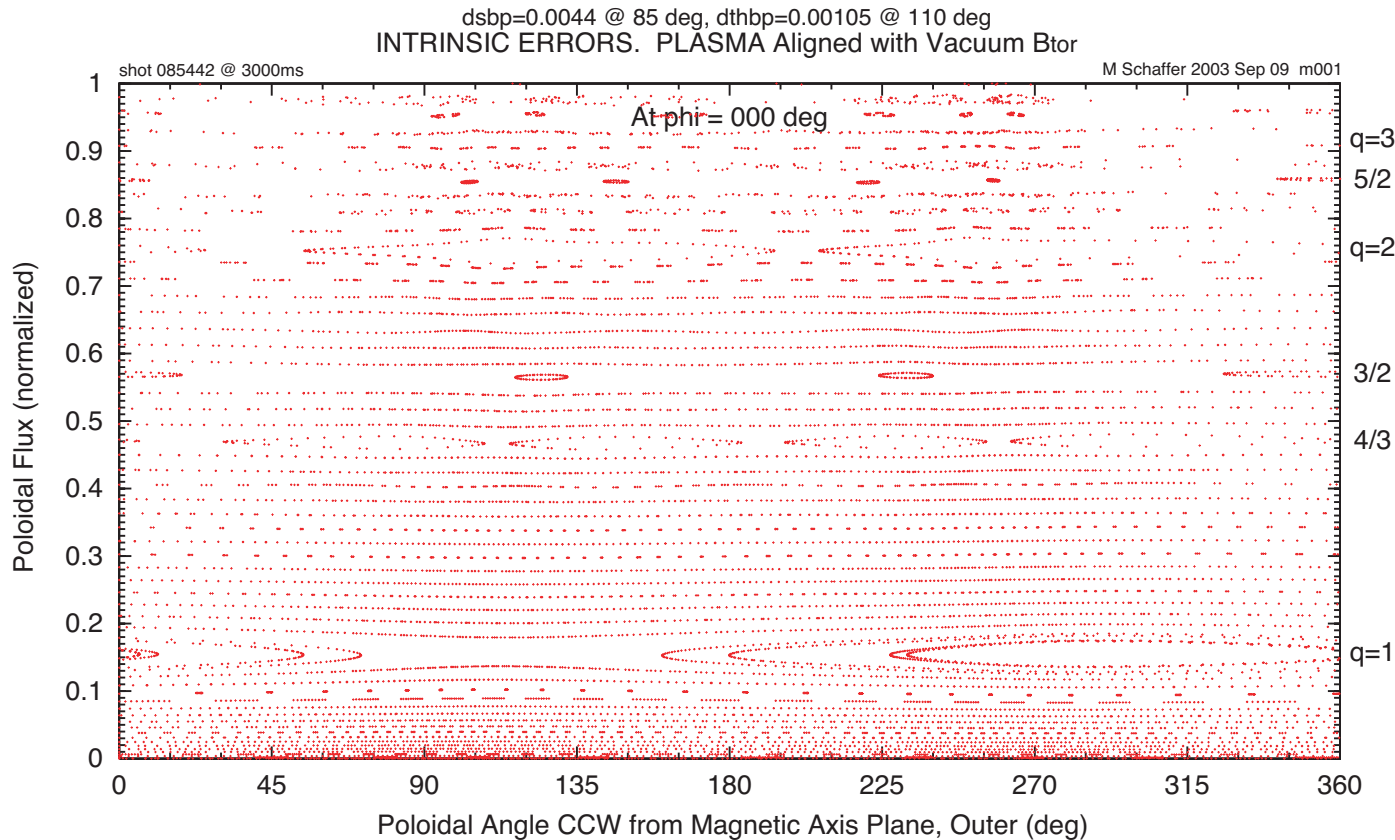

MODEL:

Measured Coil Centers,
Tilts, & Currents.
B-Coil Bus Error.

(2003)

Plasma Currents are
Aligned with Vacuum B_T .

shot 85442

- F-coil non-coaxiality error reduces bus 2,1 and 3,1 errors.
- Largest intrinsic error is 1,1 at q=1 (by Fourier analysis).

TABLE: Mode Amplitudes on q=1, 2, and 3 Surfaces

Shot 85422, Case	B·n Mode Amplitude (gauss) on Corresponding q-Surface							
	1,1	2,2	2,1	4,2	6,3	3,1	6,2	9,3
F-Coil noncoaxiality	2.44	nil	0.82	nil	nil	1.60	nil	nil
B-Coil Bus	1.70	0.33	1.56	0.41	0.51	1.51	0.41	0.63
Intrinsic Errors	1.66	0.33	0.84	0.42	0.51	0.42	0.40	0.63

Empirical C-Coil Field Makes LARGER Integer-q Islands Than the Intrinsic Vacuum Errors it is Supposed to Correct.

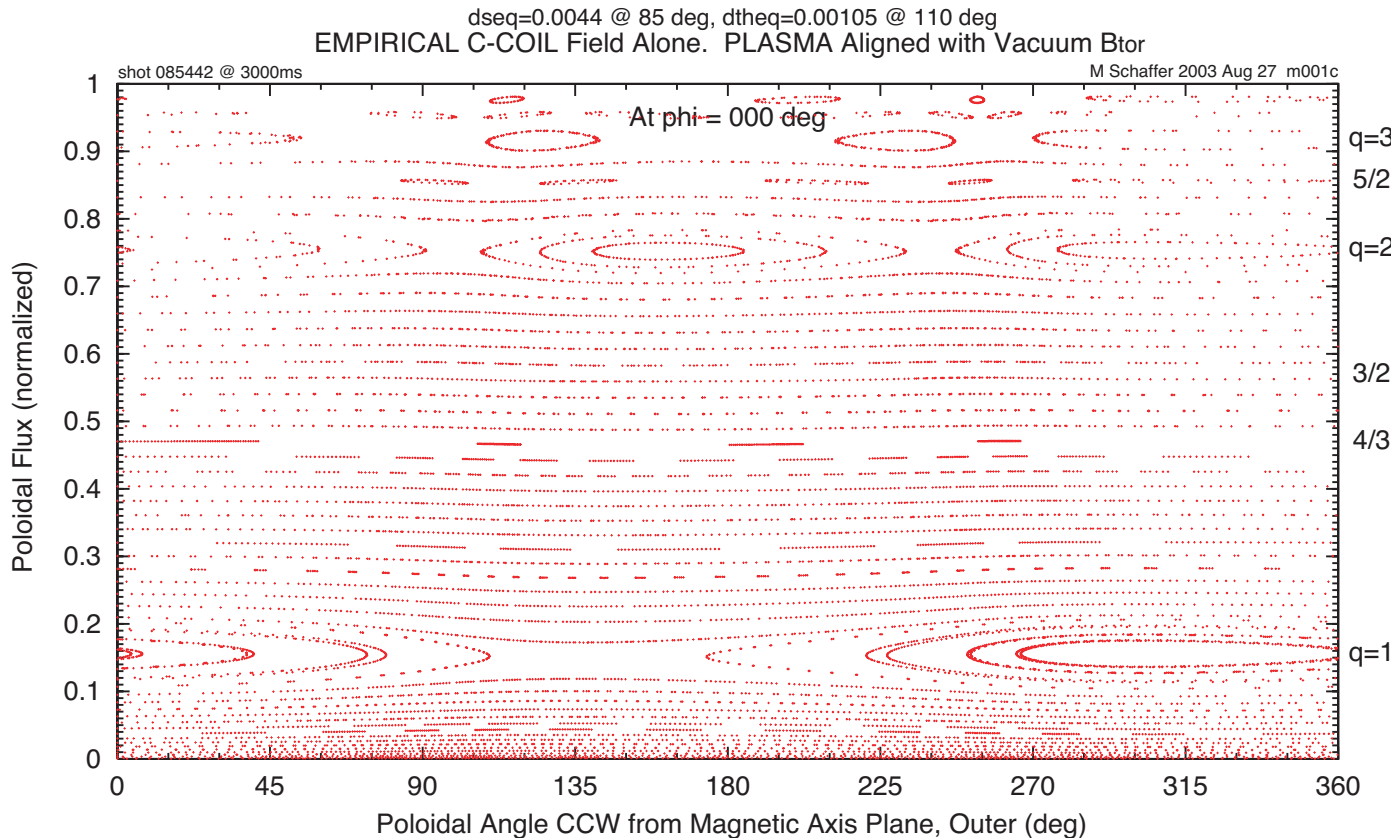

- C-coil field is *roughly* out of phase with B-coil Bus error and *roughly* in phase with F-coil non-coaxiality error.

MODEL:

Empirical C-Coil Currents. (2003)

Plasma Currents are Aligned with Vacuum B_T .

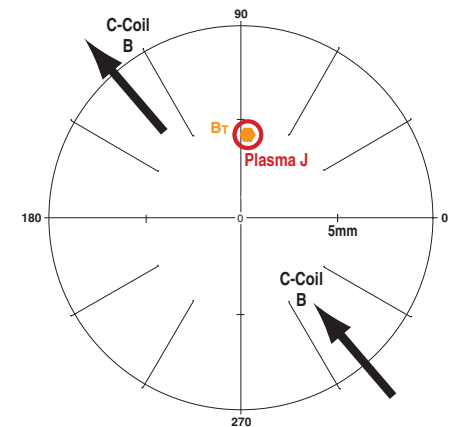

Illustrating C-Coil n=1 Field Direction. Plasma is Aligned with Vacuum B_T .

shot 85442

Combined Experimental C-Coil Field and Intrinsic Errors Make LARGE Islands, if Plasma Currents Align with B_T

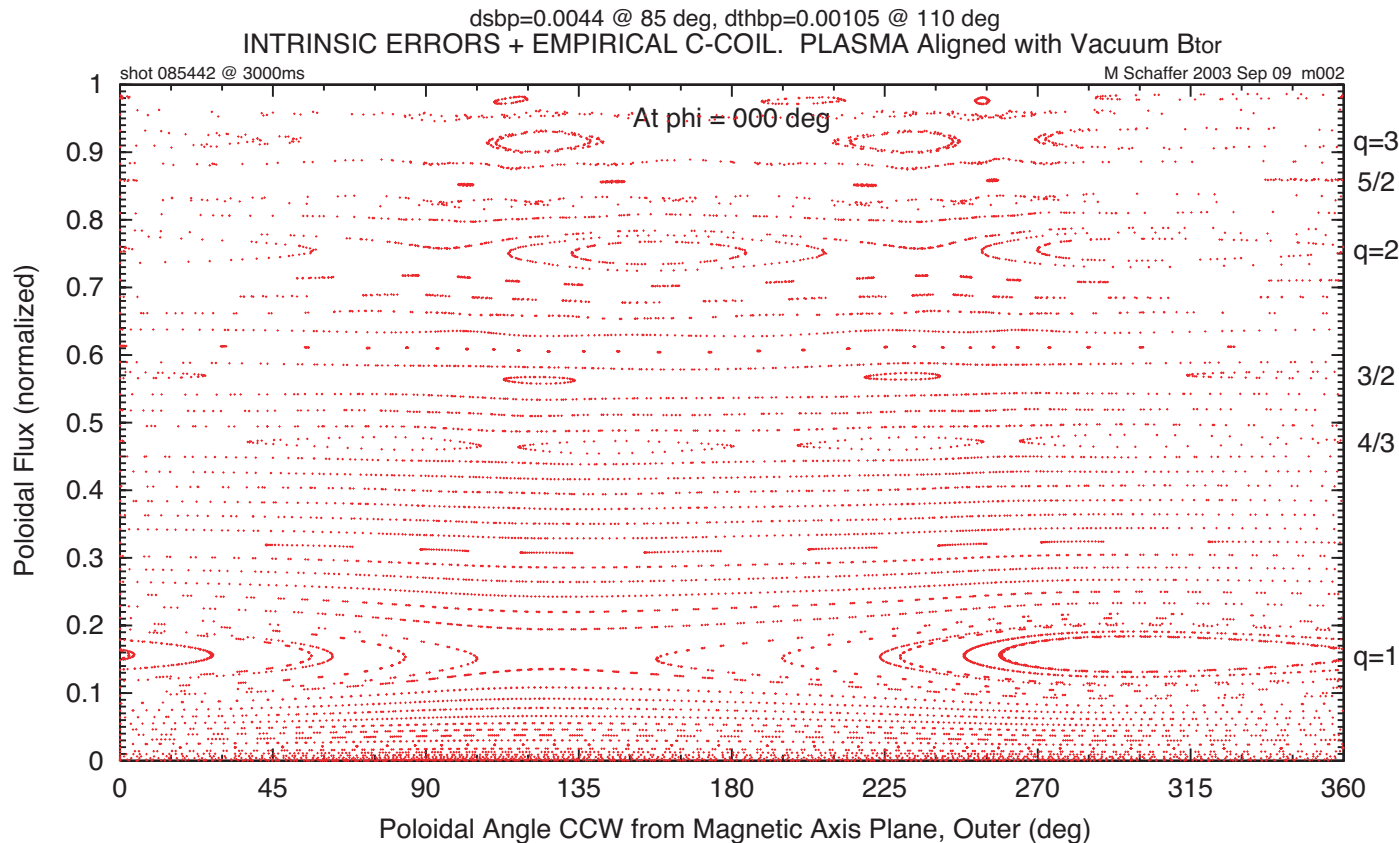

- It appears that the C-coil does not achieve its empirical correction by moving the external poloidal B so that magnetic surfaces and plasma J are \approx aligned with B_T .

MODEL:

Intrinsic Vacuum Errors
Plus Empirical C-Coil
Currents.
(2003)

Plasma Currents are
Aligned with Vacuum B_T .

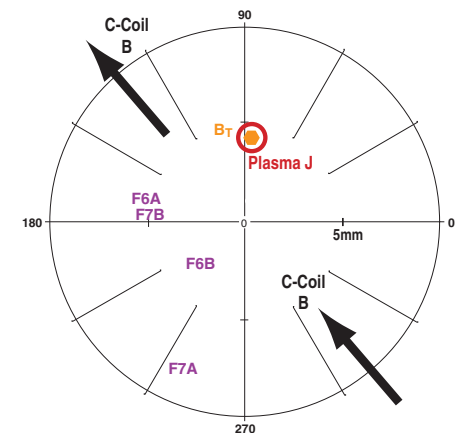

Illustrating
C-Coil $n=1$ Field Direction,
Some F-Coils,
B-Coil & Plasma Center
Locations

TABLE: Mode Amplitudes on q=1, 2, and 3 Surfaces

Shot 85422, Case	B·n Mode Amplitude (gauss) on Corresponding q-Surface							
	1,1	2,2	2,1	4,2	6,3	3,1	6,2	9,3
F-Coil noncoaxiality	2.44	nil	0.82	nil	nil	1.60	nil	nil
B-Coil Bus	1.70	0.33	1.56	0.41	0.51	1.51	0.41	0.63
Intrinsic Errors	1.66	0.33	0.84	0.42	0.51	0.42	0.40	0.63
C-Coil, Empirical	4.16	nil	3.03	nil	nil	2.93	nil	nil
Intrinsic + C-Coil	5.69	0.33	2.93	0.41	0.51	3.29	0.40	0.63

I-Coil Experiments* Imply an Effective $n=1$ Mode Locking Error in DIII-D 2~4 Times Smaller than do C-Coil Experiments

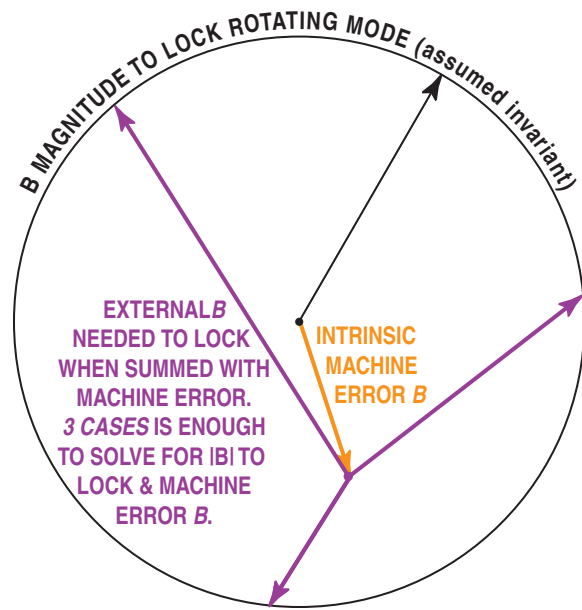

DIII-D toroidal angles viewed from above.

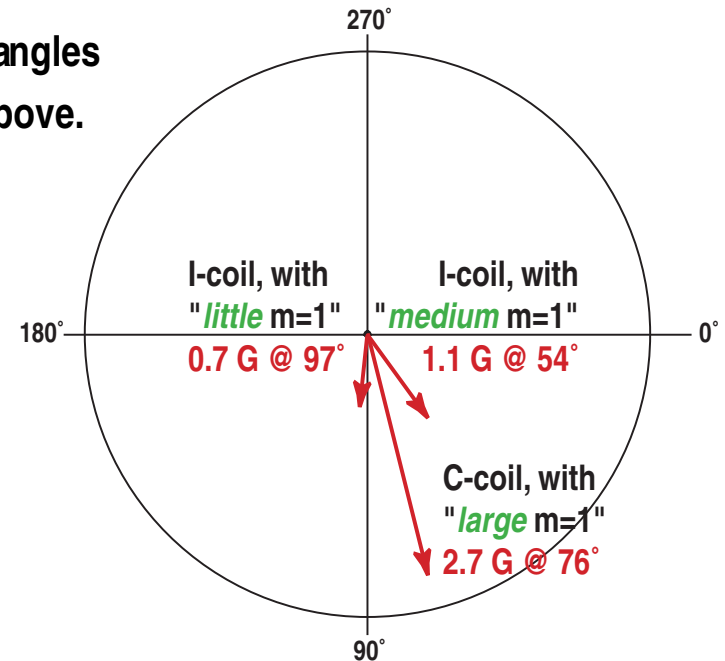

Assuming that the B magnitude-to-lock is unvarying, one can find the intrinsic B error magnitude and direction and the B magnitude-to-lock from 3 shots, applying the external B with differing toroidal phases.

I-coil was connected to make 2 different poloidal spectra, both with less $m=1$ than C-coil.

Inferred error field is not unique!
Suggests incomplete model.

Unknown error(s)?

Strong plasma response?

How Might the Empirical C-coil Operation be Working?

- Some Observations

- Empirical correction was developed for locked mode avoidance in low-density, peaked-current, saw-toothed Ohmic plasmas with $q_0 < 1$.
- Empirical correction facilitates plasma rotation.
- Empirical correction depends much more on B_{Tor} than B_{pol} .
- B-coil bus contributes \approx as much error as PF-TF coil misalignments.
- Modeling Result: C-coil algorithm applies excess $m,n = 2,1$ correction at $q=2$ surface; also makes large $1,1$ field at $q=1$ surface.
 - *Helically* deforms magnetic axis.

- Hypothesis

Empirical correction + plasma response = reduced island sizes.

Plasma deforms into an equilibrium in which B_{\perp} ($B \cdot n$) is reduced on self consistent, nonaxisymmetric, $q=1$ and/or $q=2$ magnetic surfaces.

To first order, the plasma's central current and flux surfaces respond with a small $m,n = 1,1$ helical deformation.

Rigid Plasma Response Model

- A self consistent error correction should yield (possibly perturbed, but still) nested, magnetic surfaces. No current would cross surfaces ($\mathbf{J} \cdot \mathbf{n} = 0$).
- For small perturbations a 1,1 helical deformation is like a rigid shift and tilt of the plasma's self fields.

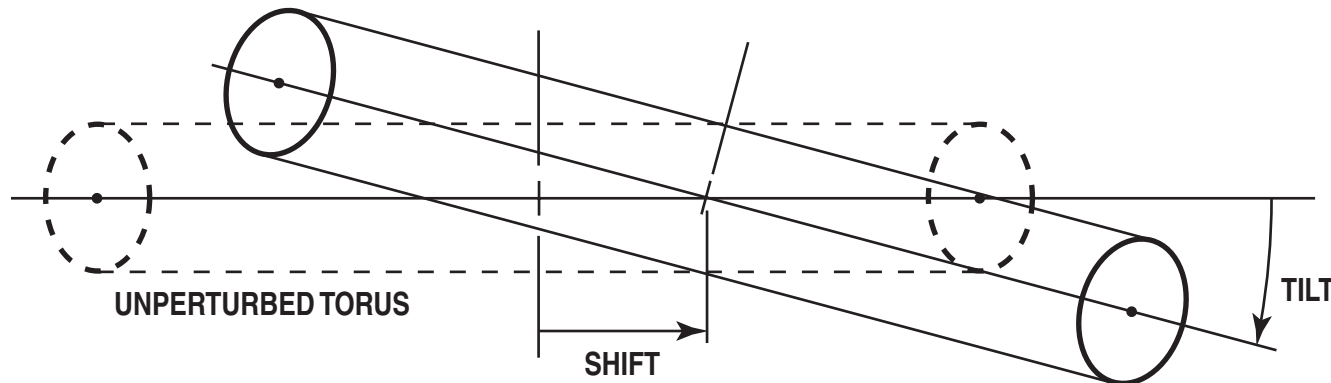

- “1,1 Consistency Model”: Minimize $\mathbf{B} \cdot \mathbf{n}$ on the perturbed $q=1$, $q=2$ and maybe $q=3$ surfaces by shifting and tilting the *PLASMA-generated* fields in the presence of the fixed, *externally generated vacuum* fields.
 - Use Fourier analysis on shifted and tilted surfaces to find a solution.
 - Verify by magnetic line tracing.

Rigid Shift & Tilt of the Plasma Currents to “1,1 Consistency” Yield Reduced-Islands in Presence of Empirical C-Coil Field

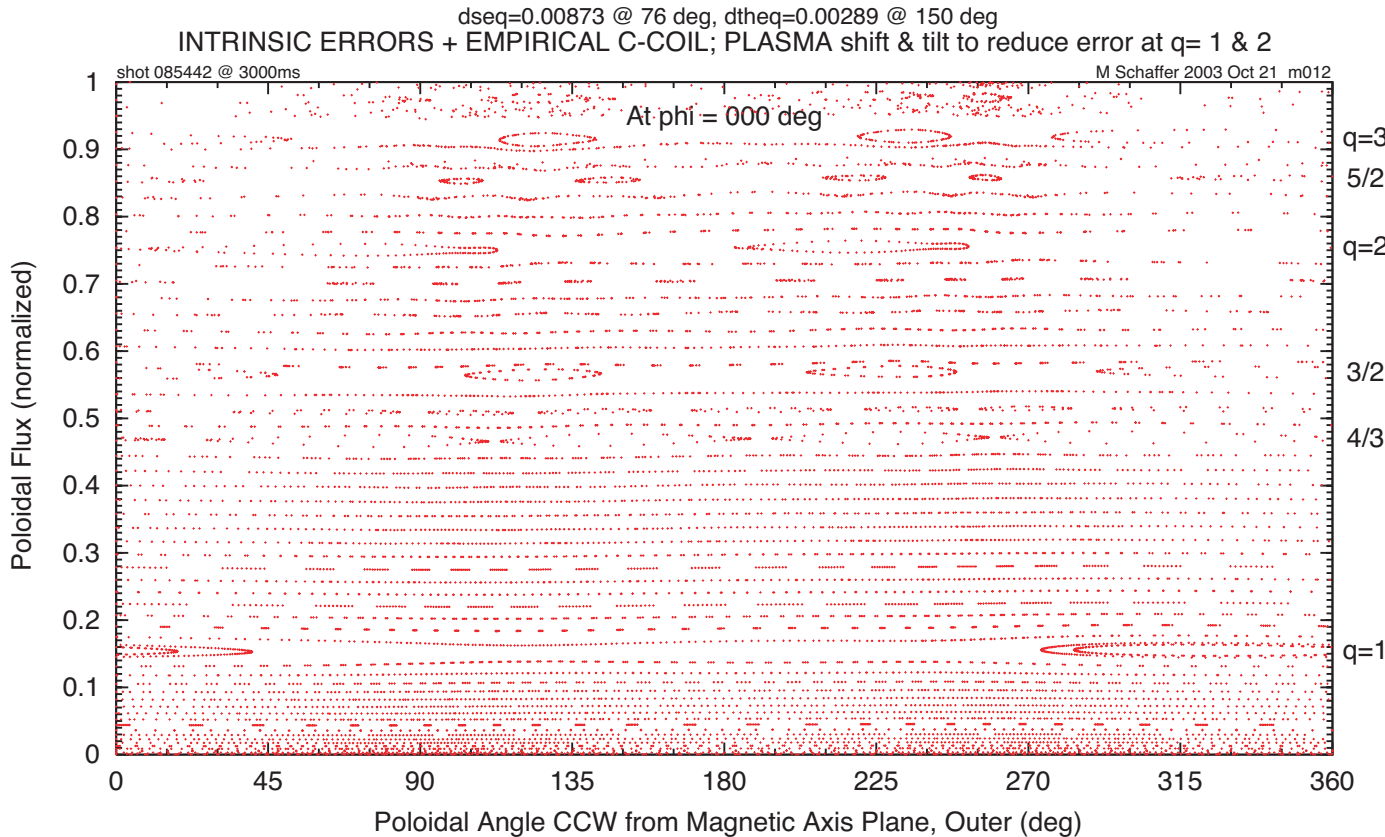

MODEL:

Shift & Tilt Plasma Currents to Align with Approximate q=1 & q=2 Magnetic Surfaces.

**Intrinsic Vacuum Errors
Empirical C-Coil Currents.**

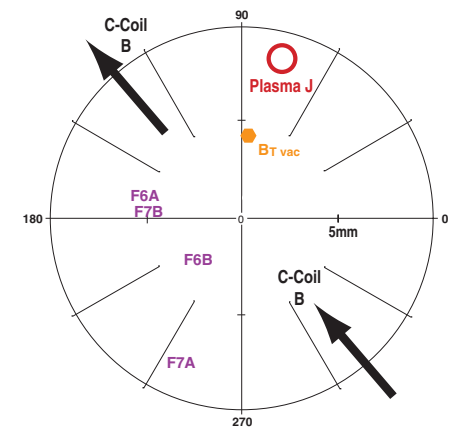

**Plasma Current
Shifted \approx 4mm, Tilted \approx 3mm
with respect to Vacuum B_T .**

- **A rigid 1,1 plasma response, with plasma current approximately aligned with magnetic surfaces, can yield a small-islands configuration, even with the C-coil “overcorrection” field.**
- **This 1,1 plasma response does not affect errors with $n > 1$.**

Rigid Shift & Tilt of the Plasma Currents to “1,1 Consistency” Also Yield Reduced-Islands with Just the Intrinsic Error

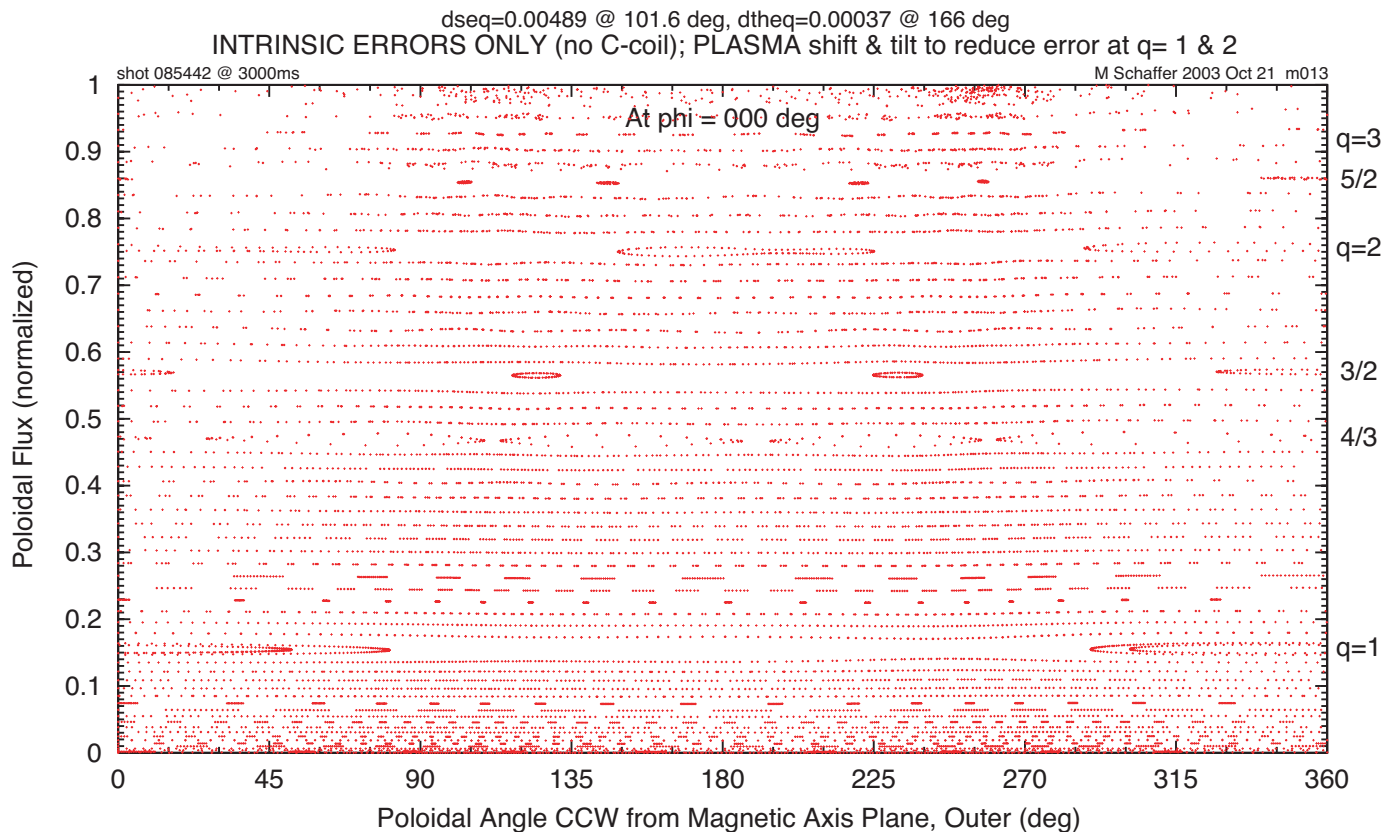

- “1,1 Consistent System” has 4 free variables: plasma shift & tilt + their 2 toroidal phases.
- Resonant errors on q=1 and q=2 surfaces: 2 magnitudes + 2 phases = 4 constraints.
- q=3 island reduction is fortuitous.

MODEL:

Shift & Tilt Plasma Currents to Align with Approximate q=1 & q=2 Magnetic Surfaces.

Intrinsic Vacuum Errors

NO C-Coil Currents.

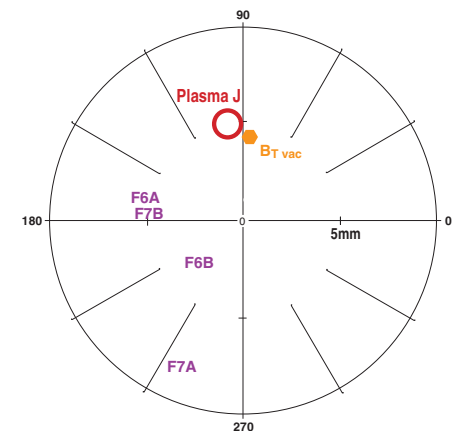

Plasma Current Shifted and Tilted $\approx 1.5\text{mm}$ with respect to Vacuum B_T .

TABLE: Mode Amplitudes on q=1, 2, and 3 Surfaces

Shot 85422, Case	B·n Mode Amplitude (gauss) on Corresponding q-Surface							
	1,1	2,2	2,1	4,2	6,3	3,1	6,2	9,3
F-Coil noncoaxiality	2.44	nil	0.82	nil	nil	1.60	nil	nil
B-Coil Bus	1.70	0.33	1.56	0.41	0.51	1.51	0.41	0.63
Intrinsic Errors	1.66	0.33	0.84	0.42	0.51	0.42	0.40	0.63
C-Coil, Empirical	4.16	nil	3.03	nil	nil	2.93	nil	nil
Intrinsic + C-Coil	5.69	0.33	2.93	0.41	0.51	3.29	0.40	0.63
1,1 Plas. Response* (with C-Coil)	0.44	0.32	0.64	0.41	0.48	1.04	0.39	0.59
1,1 Plas. Response* (without C-Coil)	0.26	0.32	0.07	0.39	0.48	0.52	0.38	0.59

*B·n errors on q=1 and q=2 surfaces were weighted by factors 0.3 and 1.7, respectively.

Discussion

- The large island reductions achievable by a simple “1,1 plasma response” model show that plasma responses of a few (< 5) mm could accommodate DIII-D plasmas to the imperfect C-coil correction field.
- But, the same “1,1 plasma response” model gives similar or better reduction of intrinsic errors, with smaller (< 2) mm plasma response.
 - Why doesn't the plasma just correct its errors without the C-coil?
 - What is the special role of the C-coil?
 - Are there other important DIII-D errors not yet modeled?
 - Are higher order plasma response terms critically important?
- For the future:
 - Investigate I-coil error correction more thoroughly.
 - Correct DIII-D bus error and learn experimentally from it.
 - Apply more sophisticated models that include MHD plasma response
 - Codes like MARS, PIES, VMEC
 - MARS physics (linearized resistive MHD, plasma rotation, viscous damping) is especially suitable for this purpose.

Summary and Conclusions

- DIII-D magnetic errors were re-measured. No large unknown errors discovered.
- Numerical models show that the EMPIRICALLY OPTIMIZED C-Coil field is too large; it over corrects the known magnetic field errors.
- A 1,1 rigid plasma response model (lowest order consistency) shows that small plasma shift and tilt can greatly reduce islands on $q=1$ and $q=2$ surfaces simultaneously and bring plasma currents (toroidal and poloidal) into close alignment with these approximate surfaces.
 - But this model predicts that the similar 1,1 response should allow the plasma to heal the errors with no external corrections applied.
 - **There is still a big fundamental puzzle.**
- We must understand how plasma responds to errors and imperfect corrections, in order to rationally design and operate correction coils in the future.

Comments on Fourier Mode Analysis on a Magnetic Surface

- I want Fourier analysis of $\mathbf{B} \cdot \hat{\mathbf{n}}$ on a surface to correspond to magnetic island properties:
 - A null of $\mathbf{B} \cdot \hat{\mathbf{n}}$ from Fourier analysis on a resonant surface must correspond to absence of an island in Poincaré plots of magnetic line trajectories.
- Procedure:
 - Set up straight-magnetic-line coordinate system on the surface: $\theta = \phi/q$
 - θ and ϕ are, respectively, poloidal and toroidal angle variables; interval = $[0, 2\pi]$
 - Must use the corresponding Jacobian when integrating over the surface:

$$J = \left(\frac{q}{R_0 B_0} \right) (R^3 B_\theta)$$

where $R_0 B_0$ = product of R_0 and toroidal B at $R = R_0$ on the surface
 R = local major radius
 B_θ = local poloidal B

First parenthesis factor of J is constant on a magnetic surface, but R^3 and B_θ vary. They reduce contributions from high field side & tips, respectively.

Thus,

$$\mathbf{B} \cdot \hat{\mathbf{n}}|_{mn} = \iint 2 \cos(m\theta + n\phi) (\mathbf{B} \cdot \hat{\mathbf{n}}) (B_\theta R^3) d\theta d\phi / \iint (B_\theta R^3) d\theta d\phi$$